

FOR CAR USE ONLY/ NUR FÜR AUTOMOBILGEBRAUCH/ POUR APPLICATION AUTOMOBILE/ PARA USO EN AUTOMÓVILES/ SOLO PER L'UTILIZZO IN AUTOMOBILE/ ENDAST FÖR BILBRUK/ ALLEEN VOOR GEBRUIK IN DE AUTO/ ТОЛЬКО ДЛЯ ИСПОЛЬЗОВАНИЯ В АВТОМОБИЛЯХ

ALPINE®

PDP-E802DSP

8 CHANNEL CLASS-D DSP POWER AMPLIFIER

- **OWNER'S MANUAL**
Please read before using this equipment.
- **BEDIENUNGSANLEITUNG**
Lesen Sie diese Bedienungsanleitung bitte vor Gebrauch des Gerätes.
- **MODE D'EMPLOI**
Veuillez lire avant d'utiliser cet appareil.
- **MANUAL DE OPERACIÓN**
Léalo antes de utilizar este equipo.
- **ISTRUZIONI PER L'USO**
Si prega di leggere prima di utilizzare il attrezzatura.
- **ANVÄNDARHANDLEDNING**
Innan du använder utrustningen bör du läsa igenom denna användarhandledning.
- **GEBRUIKERSHANDLEIDING**
Lees deze aanwijzingen aandachtig alvorens dit toestel te gebruiken.
- **РУКОВОДСТВО ПО ЭКСПЛУАТАЦИИ**
Прочтите настоящее руководство перед началом использования оборудования.

ALPINE ELECTRONICS MARKETING, INC.
1-7, Yukigaya-Otsukamachi, Ota-ku,
Tokyo 145-0067, JAPAN
Phone: 03-5499-4531

ALPS ALPINE EUROPE GmbH
Ohmstraße 4
85716 Unterschleißheim, Germany
Phone: 089-3242640

For contact information in your
respective country, please visit:
www.alpine-europe.com/distribution.html

ALPINE ELECTRONICS OF AMERICA, INC.
1500 Atlantic Boulevard, Auburn Hills,
Michigan 48326, U.S.A.
Phone 1-800-ALPINE-1 (1-800-257-4631)

ALPINE ELECTRONICS OF AUSTRALIA PTY. LTD.
161-165 Princes Highway, Hallam
Victoria 3803, Australia
Phone 03-8787-1200

ALPS ALPINE ASIA CO.,LTD.
The 9th Towers, Tower B ,floor 24th 33/4 Rama 9 road
Huay Kwang, Huay Kwang
Bangkok, Thailand 10310
Phone: +66 2-090 9596 Ex.265

EN

DE

FR

ES

IT

SE

NL

RU

CONTENTS

WARNING.....	3
SERVICE CARE	4
PRODUCT FEATURES	5
ACCESSORIES	6
INSTALLATION SEQUENCE.....	7
HARDWARE CONFIGURATION.....	8
Replacing Fuses.....	8
input configuration	10
PARALLEL MODE	10
WIRELESS MODULE.....	14
INSTALLATION.....	14
CONNECTOR PINNING	14
PC CONNECTION	15
FACTORY settings.....	16
ALPINE SOUND LAB FOR PDP-E802DSP	17
ALPINE REMOTE CONTROL APP	
FOR PDP-E802DSP	26
USB CONNECTION FOR MUSIC PLAYBACK.....	27
WIRELESS STREAMING	27
SYSTEM EXAMPLES	28
TROUBLESHOOTING	36
FIRMWARE UPDATE.....	37
SPECIFICATIONS	38

WARNING

Points to Observe for Safe Usage

Read this manual carefully before using the system components. They contain instructions on how to use this product in a safe and effective manner. Alpine cannot be responsible for problems resulting from failure to observe the instructions in this manual.

WARNING

This symbol means important instructions. Failure to heed them can result in serious injury or death.

DO NOT OPERATE ANY FUNCTION THAT TAKES YOUR ATTENTION AWAY FROM SAFELY DRIVING YOUR VEHICLE.

Any function that requires your prolonged attention should only be performed after coming to a complete stop. Always stop the vehicle in a safe location before

performing these functions. Failure to do so may result in an accident.

KEEP THE VOLUME AT A LEVEL WHERE YOU CAN STILL HEAR OUTSIDE NOISES WHILE DRIVING.

Excessive volume levels that obscure sounds such as emergency vehicle sirens or road warning signals (train crossings, etc.) can be dangerous and may result in an accident. LISTENING AT LOUD VOLUME LEVELS IN A CAR MAY ALSO CAUSE HEARING DAMAGE.

DO NOT DISASSEMBLE OR ALTER.

Doing so may result in an accident, fire or electric shock.

USE THIS PRODUCT FOR MOBILE 12V APPLICATIONS.

Use for other than its designed application may result in fire, electric shock or other injury.

USE THE CORRECT AMPERE RATING WHEN REPLACING FUSES.

Failure to do so may result in fire or electric shock.

DO NOT BLOCK VENTS OR RADIATOR PANELS.

Doing so may cause heat to build up inside and may result in fire.

MAKE THE CORRECT CONNECTIONS.

Failure to make the proper connections may result in fire or product damage.

USE ONLY IN CARS WITH A 12 VOLT NEGATIVE GROUND.

(Check with your dealer if you are not sure.) Failure to do so may result in fire, etc.

BEFORE WIRING, DISCONNECT THE CABLE FROM THE NEGATIVE BATTERY TERMINAL.

Failure to do so may result in electric shock or injury due to electrical shorts.

DO NOT ALLOW CABLES TO BECOME ENTANGLED IN SURROUNDING OBJECTS.

Arrange wiring and cables in compliance with the manual to prevent obstructions when driving. Cables or wiring that obstruct or hang up on places such as the steering wheel, gear lever, brake pedals, etc. can be extremely hazardous.

DO NOT SPLICE INTO ELECTRICAL CABLES.

Never cut away cable insulation to supply power to other equipment. Doing so will exceed the current carrying capacity of the wire and result in fire or electric shock.

DO NOT DAMAGE PIPE OR WIRING WHEN DRILLING HOLES.

When drilling holes in the chassis for installation, take precautions so as not to contact, damage or obstruct pipes, fuel lines, tanks or electrical wiring. Failure to take such precautions may result in fire.

DO NOT USE BOLTS OR NUTS IN THE BRAKE OR STEERING SYSTEMS TO MAKE GROUND CONNECTIONS.

Bolts or nuts used for the brake or steering systems (or any other safety-related system), or tanks should NEVER be used for installations or ground connections. Using such parts could disable control of the vehicle and cause fire etc.

 CAUTION	This symbol means important instructions. Failure to heed them can result in injury or property damages.
---	--

HALT USE IMMEDIATELY IF A PROBLEM APPEARS.

Failure to do so may cause personal injury or damage to the product. Return it to your authorized Alpine dealer or the nearest Alpine Service Center for repairing.

HAVE THE WIRING AND INSTALLATION DONE BY EXPERTS.

The wiring and installation of this unit requires special technical skill and experience. To ensure safety, always contact the dealer where you purchased this product to have the work done.

USE SPECIFIED ACCESSORY PARTS AND INSTALL THEM SECURELY.

Be sure to use only the specified accessory parts. Use of other than designated parts may damage this unit internally or may not securely install the unit in place. This may cause parts to become loose resulting in hazards or product failure.

ARRANGE THE WIRING SO IT IS NOT CRIMPED OR PINCHED BY A SHARP METAL EDGE.

Route the cables and wiring away from moving parts (like the seat rails) or sharp or pointed edges. This will prevent crimping and damage to the wiring. If wiring passes through a hole in metal, use a rubber grommet to prevent the wire's insulation from being cut by the metal edge of the hole.

DO NOT INSTALL IN LOCATIONS WITH HIGH MOISTURE OR DUST.

Avoid installing the unit in locations with high incidence of moisture or dust. Moisture or dust that penetrates into this unit may result in product failure.

SERVICE CARE

SERIAL NUMBER:	_____
INSTALLATION DATE:	_____
INSTALLATION TECHNICIAN:	_____
PLACE OF PURCHASE:	_____

◆ IMPORTANT

Please record the serial number of your unit in the space provided here and keep it as a permanent record. The serial number plate is located on the rear of the unit.

◆ For European Customers

Should you have any questions about warranty, please consult your store of purchase.

◆ For Customers in other Countries

IMPORTANT NOTICE

Customers who purchase the product with which this notice is packaged, and who make this purchase in countries other than the United States of America and Canada, please contact your dealer for information regarding warranty coverage.

About the software license of the product

The software installed in the product contains open-source software.

See the following Alpine website for details on the open source software.

<http://www.alpine.com/e/oss/download>

Information on disposal of old electrical and electronics equipment and batteries (applicable for countries that have adopted separate waste collection systems)



If you want to dispose this product, do not mix it with general household waste. There is a separate collection system for used electronic products in

accordance with legislation that requires proper treatment, recovery and recycling. Contact your local authority for details in locating a recycle facility nearest to you. Proper recycling and waste disposal will help conserve resources whilst preventing detrimental effects on our health and the environment.

PRODUCT FEATURES

Pure Class D amplifier technology

Alpine's PDP-E802DSP features a complete digital audio chain. Once the analogue input signal is converted to digital, the signal remains fully digital in the processing and amplification stage.

Smart high level input

The latest generation of factory car radios include sophisticated diagnosis capabilities. If a regular amplifier is connected, errors may be detected potentially leading to a shutdown of the radio's outputs. PDP-E802DSP features incorporated dummy-loads to overcome the related problems.

Start-Stop capability

The Alpine PDP-E802DSP assures a constant internal power supply, even if the battery voltage drops significantly during engine start.

Alpine Sound Lab for PDP-E80xDSP for Windows PC

A sophisticated software for setting EQ, Time Correction, Crossover and Gain. This tool was designed by the ALPINE sound team with the needs of the audiophile in mind. Wired and wireless connection available.

Alpine Remote Control App for PDP-E80xDSP for iOS and Android for Windows PC

Recall presets, change sources and control the volume right from your smartphone.

Optical input and HD Audio Streaming

High quality sources are not only limited to S/PDIF compatible devices, HD Audio content can be streamed directly to the amplifier (additional apps may be needed).

Realtime GAIN adjustment

You get immediate feedback in the Alpine Sound Lab for PDP-E802DSP (PC software) if any input channel starts clipping. You can then simply reduce the input gain of the affected channel to achieve a perfect signal match.

Power Save Mode

The Power Save Mode is automatically entered along with the Auto-Remote feature. The amplifier permanently monitors the inputs and remains switched off if no valid audio signal detected. This does significantly reduce the power in such standby state. Same for potentially connected further amplifiers. Many modern vehicle's factory radios are CAN controlled and their in-built amplifiers may unnecessarily enter/remain in ON state for a while, even if not at all in use. Conventional aftermarket amplifiers would unnecessarily switch on a drain the battery in those cases. PDP-E802DSP only turns on, if there is an audio signal being detected at its inputs.

Parallel mode

With this setting you can select the desired channel pairs to enter parallel mode. This would on the one hand reduce the number of independently available output channels, but on the other hand improve the output's damping behavior. It virtually shares the connected load among the two paralleled output's (ex. a connected 2Ω load would appear as 4Ω to each of the two paralleled outputs).

Freely configurable source routing

PDP-E802DSP's analog input signal processing allows an individual signal routing and mixing to each output channel. Mixing levels can be selected by useful percentage preset values independent for analogue, USB and Toslink sources. This makes it very easy to configure for instance a center speaker signal by simply summing up the desired input signals.

Day and Night Theme for the app

Better adjustment to the ambient brightness.

ACCESSORIES

1. DSP Amplifier PDP-E802DSP	1
2. Jumper	5
3. Power Harness 1,5m.....	1
4. Speaker Output Harness	1
5. RCA Input + Remote Harness	1
6. USB Connection Cable	1
7. RJ11 Adapter for RUX-Knob	1
8. RCA Adapter for Speaker Level In	6
9. Wireless Module (optional)	1

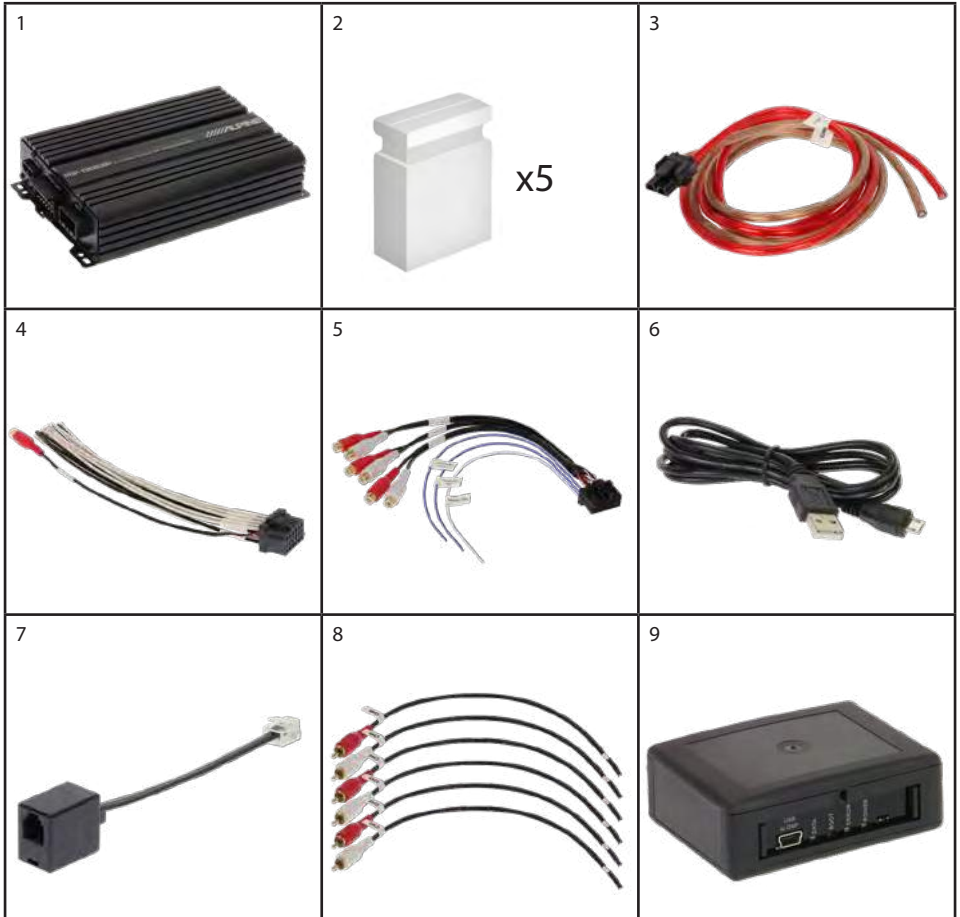

INSTALLATION SEQUENCE

Please follow the flowchart below when installing the PDP-E802DSP for the first time. Before completing the installation, we recommend to update the PDP-E802DSP to the latest firmware.

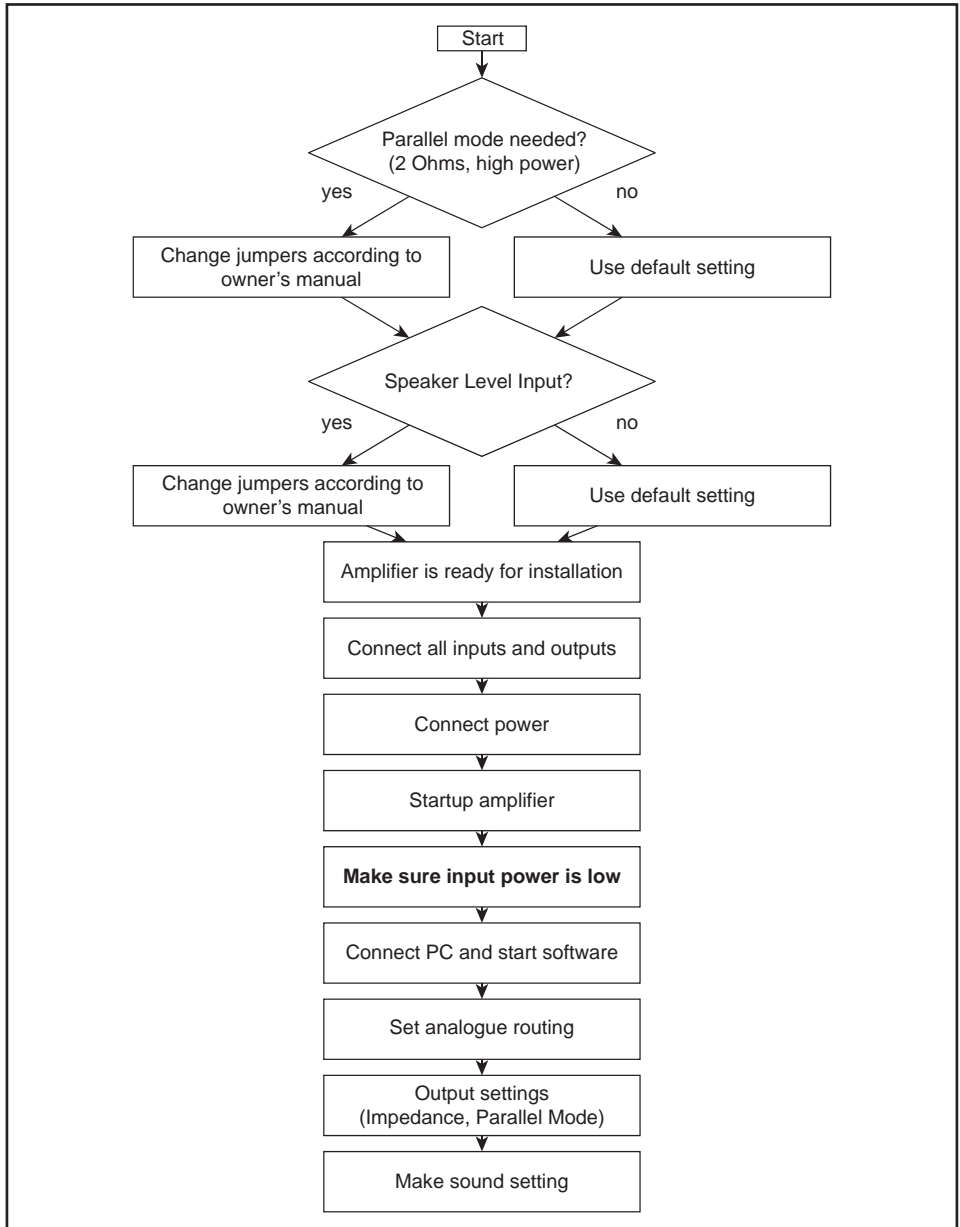

HARDWARE CONFIGURATION

This product uses semiconductors that can be damaged by electrostatic discharge (ESD).



When handling, care must be taken so that the devices are not damaged. Damage due to inappropriate handling is not covered by the warranty. The following precautions must be taken:

- Use a conductive wrist strap attached to a good earth ground.
- Always discharge yourself by touching a grounded bare metal surface or approved anti-static mat before picking up an ESD – sensitive electronic component.
- Use an approved anti-static mat to cover your work surface.

1. Remove the side panel (USB side) as shown by releasing the indicated screws.



2. Slide the bottom cover out of its guards.



3. Release the indicated screws in order to remove the digital board.



4. Flip over the digital board.

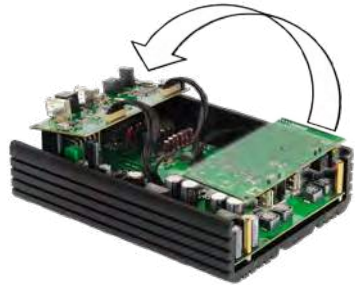

5. Now you can reach all jumpers and the fuses.

REPLACING FUSES

The main fuses are located under the bottom cover. Therefore, you must remove the side panels.



Use always the same ratings in case you have to replace them. If the fuses are frequently tripped, make sure to eliminate the cause before replacing the fuses

JUMPER LOCATIONS

Power Connector

Speaker Connector

Input Connector

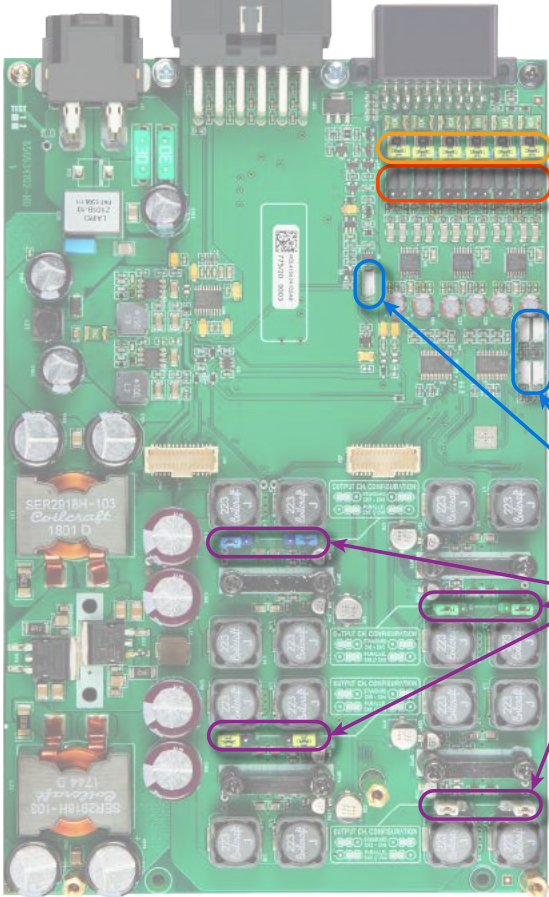

100Ω Load for Factory Unit

(see page 10)
 J32/J33 ⇨ CH1/2
 J34/J35 ⇨ CH3/4
 J36/J37 ⇨ CH5/6
 100Ω load in High mode if open
 (FACTORY DEFAULT=connected)

High/ Low Power Input

(see page 10)
 J1/J4 ⇨ Channel 1 } DC Detection
 J9/J10 ⇨ Channel 2 } capable
 J12/J13 ⇨ Channel 3
 J14/J15 ⇨ Channel 4
 J19/J20 ⇨ Channel 5 } AC Detection
 J21/J22 ⇨ Channel 6 } capable

AC Detection

(see page 24)

Parallel Mode

(see page 10)
 J7+J16 for Channel 1+2
 J8+J17 for Channel 3+4
 J25+J28 for Channel 5+6
 J24+J27 for Channel 7+8

INPUT CONFIGURATION

Set the jumpers accordig to your connection method to the headunit.

High Level inputs (speaker line)



Load Selection for High Level Inputs

If PDP-E802DSP is replacing an OEM amplifier, which has been driven by the factory headunit's speaker outputs, it is often the case that those outputs are configured in so called line driver mode. (DC bias voltage without signal vs. GND is approx. 3V.) If so, it may be required to set the corresponding PDP-E802DSP speaker inputs' impedance to 100Ω by removing the yellow jumpers in order to prevent the headunit from shutting down its speaker outputs.

Low Level inputs (RCA)

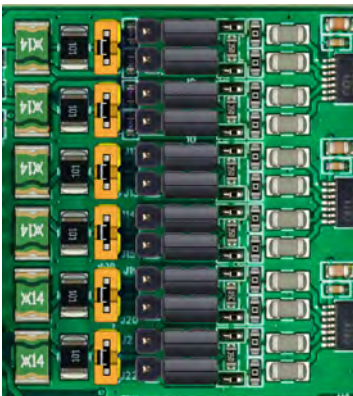

Important:

For setting the High/Low level jumpers make sure the power is disconnected.

To change the position of a jumper, it has to be removed by pulling it straight up. Make sure that the jumper is reinserted properly and all pins are fully inserted.

Default setting is low level input.

PARALLEL MODE

Depending on the system setup there are two options for driving 2Ω loads (e.g. subwoofer).

Option 1: The 2Ω driver is being connected to a single output channel.

Advantage: No reduction of available output channels. Up to 100W (RMS) into 2Ω.

Side effect: The maximum output power is also being reduced for all other channels.

Option 2: The 2Ω driver is being connected to a paralleled output channel.

Conditions: Output CH1+2 or CH3+4 or CH5+6 or CH7+8 need to be paralleled.

Advantage: Better damping factor for the connected 2Ω load.

Side effect: The total number of output channels will be reduced.

Note: Please do not to set more than 4 channels in parallel mode to avoid any overheating. This feature is intended for driving low impedance woofers of factory systems.

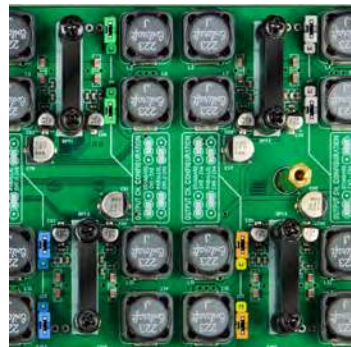

All channels are in standard mode in the above image. This is the default setting.

Example for parallel mode on channels 7+8:

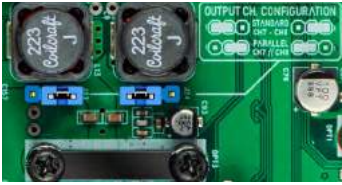

Note: Connections are not done as in regular bridged mode! Example for parallel mode on channels 7+8:

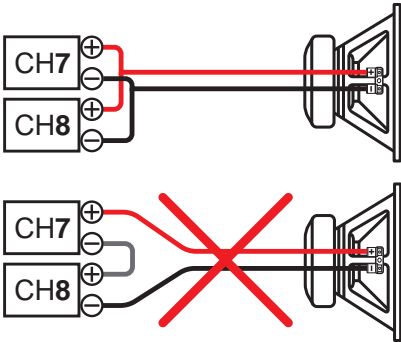

Workflow for parallel mode:

1. Disconnect the power harness.
2. Do the Hardware settings inside the amplifier.
3. Connect the speakers in parallel mode to the speaker harness (do not yet connect to the amplifier).
4. Connect the power cable and start the amp.
5. Do the software settings and store them on any preset.
6. Switch off the amplifier.
7. Connect the speaker harness to the amplifier
8. Turn on the amplifier.

BRIDGE MODE VS. PARALLEL MODE

Bridge Mode

NOT SUPPORTED BY PDP-E802DSP!

This connection equals a straight short and may break your amplifier.

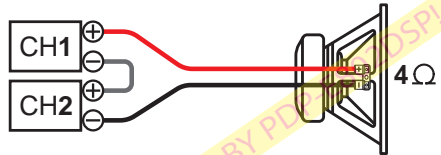

The Equivalent Circuit

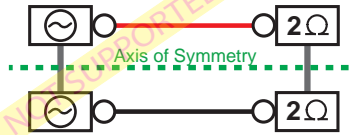

- Output Channels are connected in series
- Effective channel load impedance becomes 50% of the actually connected load.
- CH1/CH2 signals could be arbitrary and will automatically sum up (mono mix)

Parallel Mode:

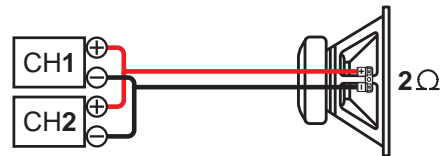

The Equivalent Circuit

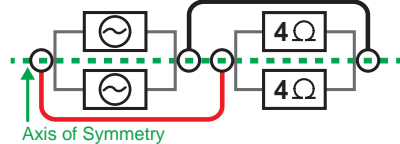

- Channels are connected in parallel and thereby share the current 50:50.
- Effective channel load impedance becomes 200% of the actually connected load.
- CH1/CH2 signals have to be 100% identical and properly paralleled closest possible to each output stage as otherwise you may break your amplifier.

CONNECTIONS

Caution: Carrying out the following steps will require special tools and technical knowledge. To avoid connection mistakes and/ or damage ask your dealer for assistance. We recommend the installation should be done by an ALPINE authorized dealer.

Fig. 2: Audio Connections
Please refer to Fig. 2

1 Battery Lead Connector

2 Speaker Output Connector

Important: We highly recommend doing the general settings in the Alpine Sound Lab for PDP-E802DSP before the first start up (see "Amplifier Setting Tab" on page 23). An incorrect setting may destroy your tweeters. Make sure the source volume is set to 0 when starting up the PDP-E802DSP for the first time.

3 Input Connector

4 21 9 RCA Input Channels 1 - 6

6-channel input (low level), for connection to signal sources with any output level. Please configure high or low power using the jumpers inside the amplifier. Default setting is low level. Use the correct cable (RCA/cinch cable) to connect these inputs to the pre-amplifier / low level outputs of your head unit. Each input can be assigned to any output using the Alpine Sound Lab for PDP-E802DSP software. The autosensing function has also to be configured within this app.

10 Remote Input

The remote input line shall be used for switching the amplifier on/off. It is not recommended controlling the remote input via the ignition switch as this may cause pop noise during turn on/off.

The Auto-Remote feature needs to be configured in the Alpine Sound Lab for PDP-E802DSP software.

11 Remote Output

The remote output line can be used for switching on/off further amplifiers.

12 Preset Toggle

When positive trigger is applied, PDP-E802DSP will switch to preset 6 (Trigger voltage = 2.5VDC or more).

13 Pre-Out Jack

This is an ideal output for driving a separate subwoofer amp. The 1-channel RCA output is fully processed and a straight "copy" of speaker output channel 8. An optionally connected amplifier should be able to handle input signals of up to 2V RMS. We do recommend connecting high quality amplifiers with differential RCA input/s (ground isolated) in order to avoid unwanted noise.

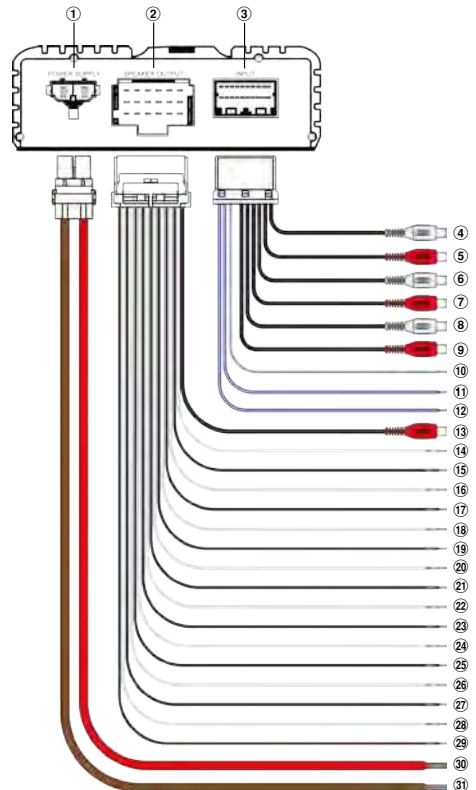

14-29 Output Channels 1 - 8

Amplifier outputs that are connected to the speakers. The minimum impedance per channel is 2 Ohms. Please configure your system impedance using the Alpine Sound Lab for PDP-E802DSP (See "2 Speaker Load Setting" on page 23).

Never connect any of the speaker cables with the chassis ground as this will damage your amplifier and your speakers. Make sure that all speakers are connected in phase.

30 Battery Cable (+)

Be sure to add an External Fuse (e.g. Fuse Block, Circuit Breaker) to the battery lead no further than 30cm from the battery's positive (+) terminal. This fuse will protect your vehicle's electrical system in case of a short circuit. Appropriate fuse value requirement: 60 A fuse.

31 Ground Cable (-)

The ground cable should be connected to a common ground reference point (this is located where the negative terminal of the battery is grounded to the metal body of the vehicle) or to a prepared metal location on the vehicle chassis i. e. an area which has been cleaned of all paint residues.

Fig. 3: Other Connections

Please refer to Fig. 3

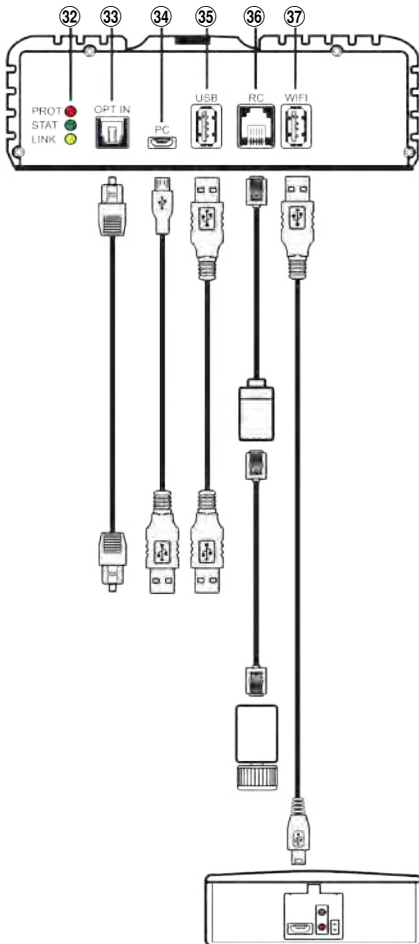

32 Status Indicators

Red: The LED indicates:

- Startup and shutdown process
- Analogue input clipping
- Thermal/ Power protection triggered
- Toslink not locked (if source set to Toslink)

Green:

- The amp is switched ON and in normal operation.
- Indicates DSP configuration OK at startup

Flashing: communication with PC/ Phone

Yellow: The amp is connected to a computer by USB or Wi-Fi.

33 Optical Digital Input

Optical input to connect S/PDIF sources. The sampling rate for this input must be between 12 and 96kHz. The input signal is automatically converted to the internal sampling rate.

You can select the Digital input by using the remote app.

Caution: The signal of a digital audio source normally does not contain any information about the volume level. In this case the amp will perform at maximum output level. This may damage your speakers. It is recommended to use the ALPINE remote app or the wired RUX-Knob.

Note: The Alpine PDP-E802DSP amp can only handle uncompressed digital stereo signals in PCM format with a sampling rate between 12kHz and 96kHz. No Dolby coded signals.

34 Micro USB Connection

Connect your personal computer or smart phone. See "PC CONNECTION" on page 15 and "USB Connection for Music Playback" on page 27.

The required PC software (Alpine Sound Lab for PDP-E802DSP) to configure this amplifier can be downloaded from your local Alpine website.

Please note: It is not possible to connect any USB storage devices.

35 USB Connection

For future applications.

36 Remote Volume Control

This input is designed for the Alpine RUX-Knob which allows you to adjust the main volume or subwoofer volume. The functionality must be defined in the „Amp Settings“ within the PC app.

37 USB Port for Wireless Module

Connect the optional wireless module using the supplied USB cable. The wireless module will enable the wireless connection of a PC or smart phone using the respective apps. It can also be

used for the remote app or streaming audio content.

WIRELESS MODULE

The optional module WAD-PDP1 is made for wireless control by Alpine Sound Lab for PDP-E802DSP and for the Alpine remote app (available in appstores for Android and IOS). You can also stream audio files from your smartphone to the amplifier.

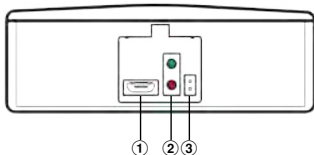

1 Micro USB connection to amplifier

2 Status LEDs

Green: On

Red: Data transfer

3 Reset

Apply a jumper for 4 seconds to reset.

INSTALLATION

Due to the high power output of the PDP-E802DSP considerable heat is produced when the amplifier is in operation. For this reason, the amplifier should be mounted in a location which will allow for free circulation of air, such as inside the luggage area. For alternative installation locations, please contact your authorized Alpine dealer.

- Using the amplifier as a template, mark the four screw locations.
- Make sure there are no objects behind the surface that may become damaged during drilling.
- Drill the screw holes.
- Position the PDP-E802DSP over the screw holes, and secure with four self-tapping screws.

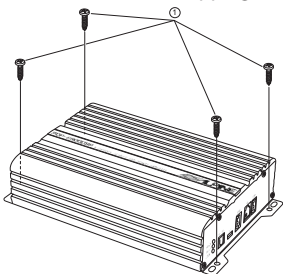

CONNECTOR PINNING

View from cable side.

Power Harness

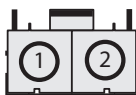

PIN	Color	Function
1	Red	Battery +
2	Brown	Ground -

Input Connector

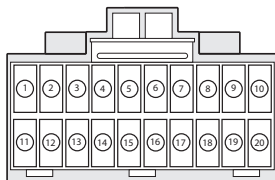

PIN	Color	Function	PIN	Color	Function
1	Black	Ch. 1 Ground	11	White	Ch. 1 Signal
2	Black	Ch. 2 Ground	12	Red	Ch. 2 Signal
3	Black	Ch. 3 Ground	13	White	Ch. 3 Signal
4	Black	Ch. 4 Ground	14	Red	Ch. 4 Signal
5	Black	Ch. 5 Ground	15	White	Ch. 5 Signal
6	Black	Ch. 6 Ground	16	Red	Ch. 6 Signal
7		NC	17		NC
8		NC	18		NC
9	White/Blue	PresetToggle	19		NC
10	Blue/White	Remote Out	20	Blue/White	Remote In

Output Connector

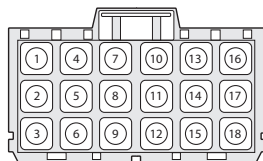

PIN	Color	Function	PIN	Color	Function
1	White	Ch. 1 -	10	White	Ch. 6 -
2	Black	Ch. 1 +	11	Black	Ch. 6 +
3	White	Ch. 2 -	12	Black	Ch. 5 +
4	White	Ch. 3 -	13	White	Ch. 7 -
5	Black	Ch. 3 +	14	Black	Ch. 7 +
6	Black	Ch. 2 +	15	White	Ch. 8 -
7	White	Ch. 4 -	16	Black	Line Out -
8	Black	Ch. 4 +	17	Red	Line Out +
9	White	CH. 5 -	18	Black	Ch. 8 +

PC CONNECTION

Minimum system requirements:

- Windows 10
- 32 and 64bit systems are supported
- 1,2Ghz; 1GB of RAM; 1GB of HDD space
- Latest .NET Framework (v 4.7.1 or higher)
- Minimum Display resolution: 1280x800

Software Installation:

You can download the Alpine Sound Lab for PDP-E802DSP software and the device driver from your local Alpine website. The file can be found in the support section.

The website will also contain short video clips explaining the process step-by-step.

- Download the installation files
- Unpack the zip file
- Run the setup wizard

Screenshots from Windows Installation Process:

1



2

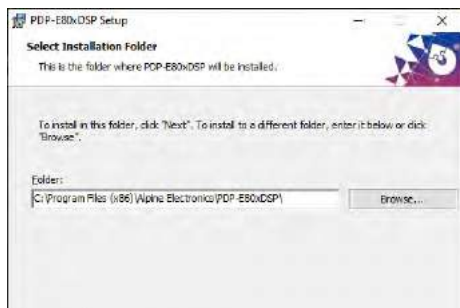

3

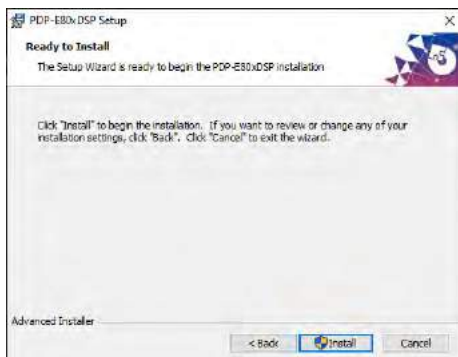

4

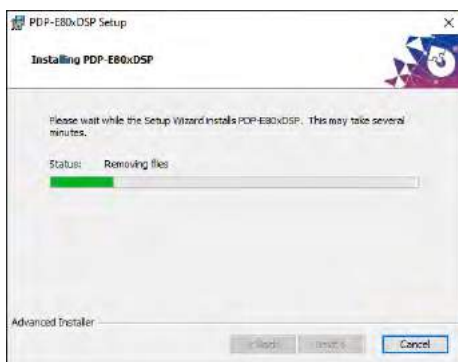

5

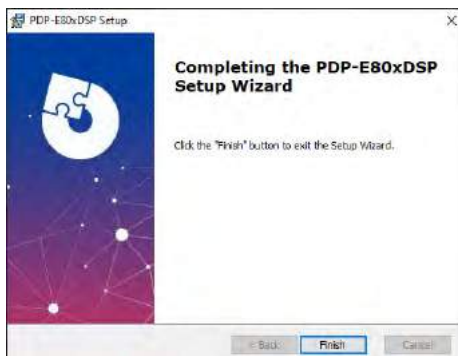

Caution:

It is highly recommended to set the volume of your car source to minimum position during the first start-up. Additionally, no devices or speakers should be connected to the amplifier until general settings in the Alpine Sound Lab for PDP-E802DSP software have been made. Especially when the PDP-E802DSP is used to drive a fully active speaker system. Wrong settings can destroy your tweeters right away.

Connect your PC to the PDP-E802DSP:

- Connect your PC with the supplied micro USB cable.

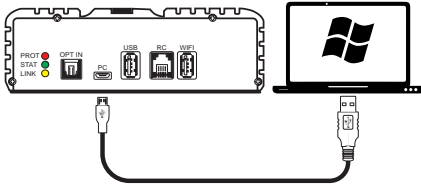

- If you haven't done so, connect power to the PDP-E802DSP. If the amplifier is not switched on when the PC connection is established, the PDP-E802DSP will go to the 'update mode'.
- Start the software by double clicking the Alpine Sound Lab for PDP-E802DSP Icon on your PC.



- To activate communication to the PDP-E802DSP simply press the power icon. The power icon will also change from being grey to being blue



Not Connected



Connected

Select „Yes“ in the pop-up window. The DSP amp is now ready for the system configuration to be started.

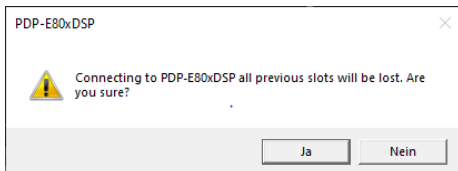

FACTORY SETTINGS

- Input = RCA
- No parallel mode, 8 straight channels
- Input channels 1+2 linked to all output channels
- Analogue input source active
- Remote on by wire
- Highpass for all channels to protect speakers

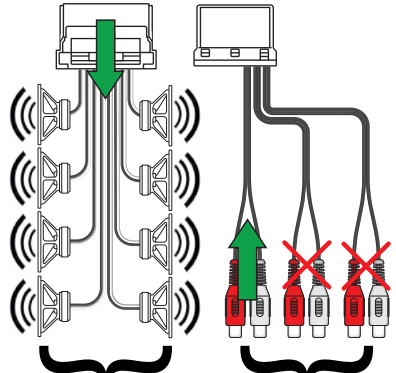
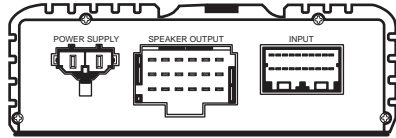

All channels are feed with the signal from input 1+2.

By default only channel 1+2 are active.

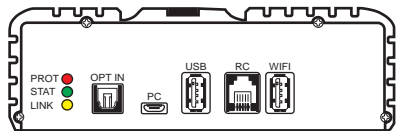

ALPINE SOUND LAB FOR PDP-E802DSP

Tuning Tab

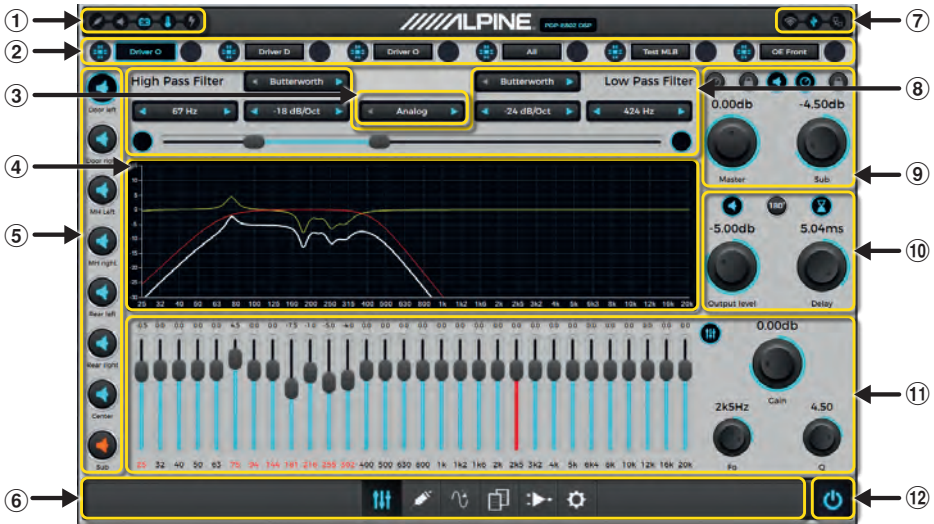

① Status Bar

② Preset Bar

③ Source Selection

④ Graphical Representation of Settings

⑤ Channel Bar

⑥ Tab Bar

⑦ Connection Bar

⑧ Crossover Settings

⑨ Master/ Sub Volume Settings

⑩ Channel Gain and Time Correction Settings

⑪ Equalizer Settings

⑫ ON/OFF Switch (starts PC connection)

① Status Bar

	Red: Clipping on analogue input
	Red: Clipping on speaker output
	Battery status: Blue=OK; Red = Low
	Temperature: Blue=OK; Red = Overheat
	Short circuit on an output line

② Preset Bar

	On: Preset selected Off: Preset not selected
	DSP Icon Blue: Memory and current settings are the same.
	Grey: Memory saved but current settings are different.
	Lock Icon Blue: You are the creator of the settings and have full access.
	Red: Settings are secured, you have only limited access.

③ Source Selection

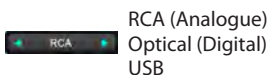

④ Graphical Representation of Settings

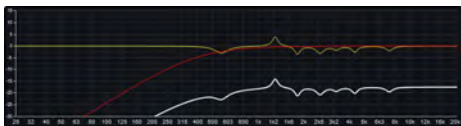

⑤ Channel Bar

	LED Ring Off: Channel not selected
	Blue: Channel selected
	Yellow: This channel is linked to the selected channel.
	Speaker Icon Grey: Channel muted
	Blue: Channel active
	Orange: Channel configured as subwoofer, subwoofer level control is active.

Channel Settings:

A right click on a speaker icon will show a context menu with the options described below:

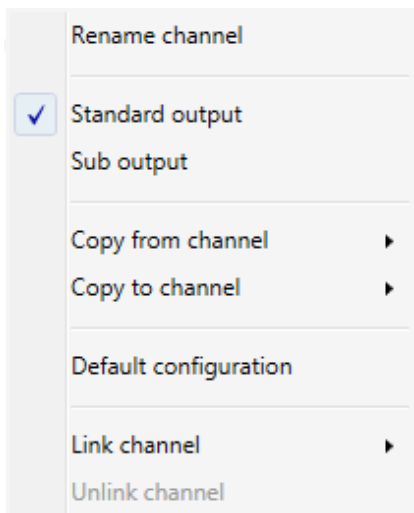

Rename channel:

All channels can be renamed, like FL Mid-High, Sub 1 etc. Be aware that the labels of the

channels will only be valid during the current session.

Standard output:

The channel is linked to the master volume controller.

Sub output:

The channel is linked to the subwoofer volume controller.

Copy from channel:

You can copy the settings to the selected channel.

Copy to channel:

Allows to transfer the settings to the selected channel.

Default configuration:

Reset the channel to default. All settings are deleted.

Link channel:

You can link 2 channels. All settings will be copied to the linked channel. This is a common way for dual subwoofers.



⑥ Tab Bar

	Tuning tab
	Input tab
	Time correction tab
	Overview tab
	Amplifier setting tab
	App setting tab

⑦ Connection Bar



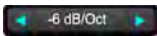
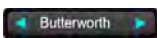

	On when wireless connection is established.
	On when PC is connected via USB.
	On when data is being transferred to the PDP-E802DSP.

⑧ Crossover

	Selection of crossover frequency
	Slope selection (0 up to -30 dB/Oct. possible)
	Filter characteristics (Butterworth, Bessel, Chebyshev)
	Slider bar for quick crossover selection
	Crossover on/ off

⑨ Master/ Subwoofer Volume Setting



Master volume and level control subwoofer channels.

	Volume settings are locked.
	Blue: All channels are active.
	Grey: All channels are muted.
	On: Remote volume knob enabled (either Master or Sub). Optional RUX-KNOB required.







⑩ Volume/ Delay Setting

Gain, time delay and phase inversion for the selected channel.



	Select channel muting on/ off.
	Select phase inversion on/ off.
	Select channel time delay on/ off.

⑪ Equalizer Settings

30 Band Parametric EQ for the selected channel.

	Gain Setting + 10dB/ -30dB
	Center Frequency Setting 400Hz Fo
	Q Factor Setting 1 (wide) - 15 (narrow) Q
	Select equalizer on/ off.

⑫ ON/OFF Switch (starts PC connection)

	Off: no connection between PC and amplifier.
	On: connection between PC and amplifier established.

Adjustment of the rotary controllers

a) by mouse

b) by cursor keys

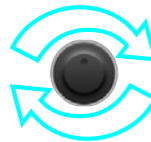

Unused Channels:

- We recommend to use all available channels, i.e. by using the parallel mode.
- When this is not possible, set the unused channel to maximum attenuation ($-\infty$ dB). This will help to avoid wrong tripping of any protection mode.

Input Tab



① Gain Settings (-6dB - +12dB)

For a perfect input sensitivity setting to your audio source check the following steps.

1. Don't connect any amplifiers or loudspeakers to the outputs of the ALPINE PDP-E802DSP during this setup.
2. Make source input connections
3. Do the jumper settings (high or low power, AC/DC Detection, input load)
4. Turn on the amplifier
5. Adjust the source volume to 90% of the max. Volume and playback a 1 kHz test tone (0dB) via CD drive.
6. If the PROT LED already lights up, decrease the input sensitivity within the app until the PROT LED turns off.

With this setting you are matching your source to the amplifier. Higher gain does not mean higher output power.

Note: the gain setting adapts the source volume to the input of the amplifier. It does not set the amplification factor. Suggested gains listed in the table on next page.

② Extra Gain

When the digital source appears not as loud as other sources, the gain can be raised by using this setting. Depending on the mastering of the source material, there is risk of clipping when the Extra Gain was raised.

③ Enable Inputs

With this menu you can enable/ disable the inputs of your amplifier.

④ Analogue Routing

With this matrix you can setup which input channel is routed to which output channel in percent. Using this method, you can simply create a virtual center channel by applying 50% left signal and 50% right signal. Every channel should have 100% signal in total for a proper use.

		Inputs						Total
		CH 1	CH 2	CH 3	CH 4	CH 5	CH 6	
Outputs	CH 1	100	0	0	0	0	0	100
	CH 2	0	100	0	0	0	0	100
	CH 3	0	0	100	0	0	0	100
	CH 4	0	0	0	100	0	0	100
	CH 5	100	0	0	0	0	0	100
	CH 6	0	100	0	0	0	0	100
	CH 7	25	25	25	25	0	0	100
	CH 8	0	0	0	0	0	100	100

⑤ USB Routing

		Inputs		Total
		CH 1	CH 2	
Outputs	CH 1	100	0	100
	CH 2	0	100	100
	CH 3	100	0	100
	CH 4	0	100	100
	CH 5	100	0	100
	CH 6	0	100	100
	CH 7	50	50	100
	CH 8	50	50	100

⑥ Toslink Routing

		Inputs		Total
		CH 1	CH 2	
Outputs	CH 1	100	0	100
	CH 2	0	100	100
	CH 3	100	0	100
	CH 4	0	100	100
	CH 5	50	50	100
	CH 6	100	0	100
	CH 7	50	50	100
	CH 8	50	50	100

Headunit Connection	Input Configuration	Yellow Jumper	Input Gain
Pre Out 2V	Low	plugged	0dB
Pre Out 4V	Low	plugged	-6dB
Headphone out 500mV	Low	plugged	+12dB
BTL Speaker Out (25W@4 Ohms)	High	plugged	0dB
Single Ended Speaker Out (6W@4 Ohms)	High	plugged	+6dB
Line driver mode (for driving OEM amplifier)	High	removed	+6dB
OEM Amplifier output (80W@4 Ohms)	High	plugged	-6dB

Time Correction Tab

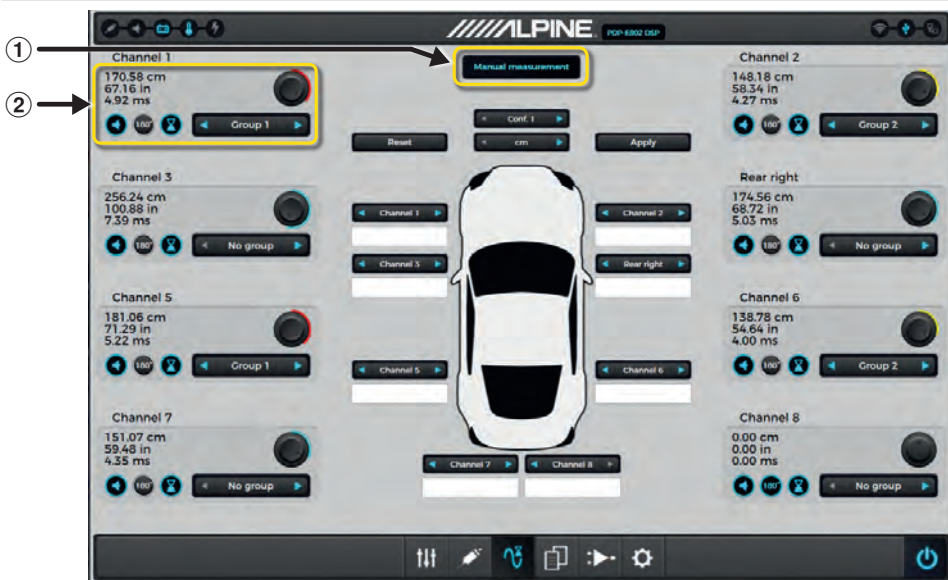

The time correction allows individual adjustments for each speaker output to align the different distances of each speaker relative to the listener's position inside the cabin. Adjustments can be done for level, delay and phase (0°/180°)

① Assistance for time delay adjustment

A very accurate automatic time delay calculator is built directly into the app. To begin this setup, you have to measure the physical distance of each speaker in the system that has been assigned to an output channel. Verify that your measurement value is correct. Assign each speaker location to an output channel. Enter the measurement of each speaker's distance to the driver's seat headrest. When all values have been entered simply press the "APPLY" button to store these measurements into each output channel the PDP-E802DSP.

The rotary knobs can still be used to make even finer adjustments if required.

② Delay Setting

Allows adjustment of each independent output channel audio signals to compensate for the differences of poor speaker placement, relative to the driver's seating position in vehicles. For the selected channel volume, delay setting and Phase inversion 180° can be adjusted.

Group 1	The group selection allows you to create up to 4 different delay groups. Changes will affect all channels allocated to the group.
	Channel muting on/ off
	Phase inversion on/ off
	Channel delay on/ off

Overview Tab



This screen visualizes the response curve(s) of the selected user adjustments of crossover, EQ, TCR and level for each output channel. The parameters and channels to be reflected in the visualization can be selected in the upper screen area by toggling the selection boxes.

<input type="checkbox"/> OFF	No channel information selected.
<input checked="" type="checkbox"/> Full	All settings are shown in the graphic display (EQ, crossover, level).
<input checked="" type="checkbox"/> Crossovers	Only crossover graphic is shown.
<input checked="" type="checkbox"/> EQs	Only EQ settings of the selected channel are shown.

Amplifier Setting Tab

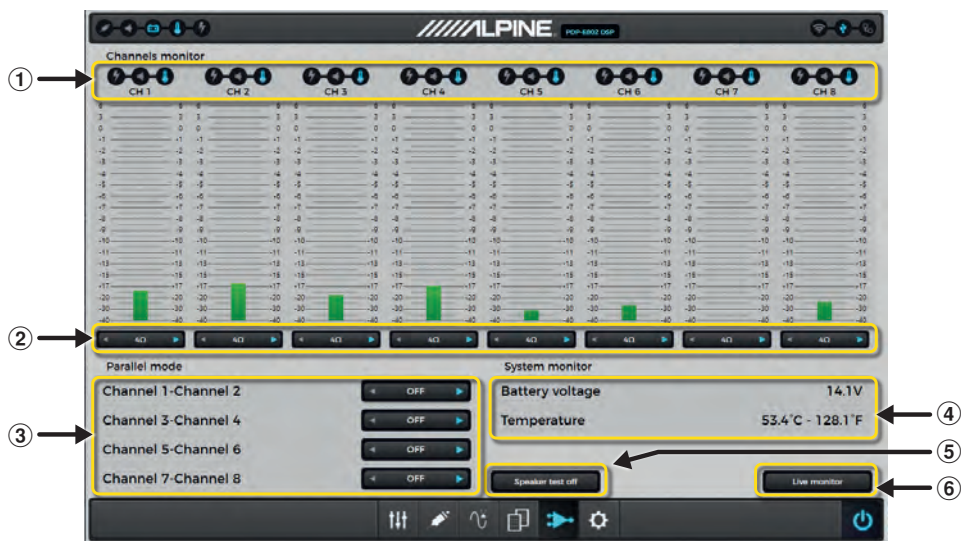

① Channel Status

The status of each channel is shown by the three indicators below.

	Red: Short circuit on an output line
	Red: Clipping on speaker output
	Battery status: Blue=OK; Red = Low

② Speaker Load Setting

You need to select the speaker load being connected to each output for power supply matching. Connecting lower impedance loads (ex. 2Ω) will result in an appropriate internal voltage adjustment. In case of mismatches, the following protection mechanisms may automatically apply:

1. The amplifier will reduce the output power.
2. The amp shuts down to safe mode. The amp will only recover after reboot (off/on). Impedance settings are to be carefully reviewed in such case.

③ Parallel Mode

With this setting you can select the desired channel pairs to enter parallel mode. This would on the one hand reduce the number of independently available output channels, but on the other hand improve the output's damping behavior. It virtually shares the connected load among the two paralleled

outputs (ex. a connected 2Ω load would appear as 4Ω to each of the two paralleled outputs). See page 10 for details.

④ System Monitor

This section allows to check the battery voltage of the vehicle and the temperature of the amplifier.

⑤ Speaker Test

In order to protect your equipment from wrong connections, the PDP-E802DSP checks the impedance of all speakers. If you think there is a mis-detection, i.e. all wirings etc. are correct, switch off the "Speaker Test" feature.

⑥ Live Monitor

This tool allows you to monitor the average temperature and voltage over a period of 1, 3 or 5 minutes.



Application Setting Tab



① DSP Status

This section shows the serial number of the amplifier and the firmware version.

	It is possible to delay switching on and off the amplifier between 1s and 10s.
	The Autoremove feature allows to switch on the amplifier by detection of an audio signal. This may help in cars where no amplifier turn on signal is available. Options: OFF (default), AC, DC

Autoremove OFF:

The PDP-E802DSP will be switched on by the remote wire.



Autoremove AC detection:

In this mode, the PDP-E802DSP will detect an audio signal from a source that is connected to channels 5+6. Jumpers J2, J3, J5, J6, J38 must be connected.



Time ON:

Here you set the duration of the input signal to be continuously detected above the threshold limit prior to turning ON.

Threshold ON:

Here you set detection signal level for turning ON.

Time OFF:

Here you set the duration of the input signal to be continuously detected below the threshold limit prior to turning OFF.

Threshold OFF:

Here you can set detection signal level for turning OFF.

Note:

The Threshold ON value should be always be bigger than Threshold OFF.

Tech Tip:

If the amp is connected by USB wire and turns off during the autoremove settings the amp falls in Update mode. To restart the amp you have to disconnect the USB and start the amp by cycling power OFF/ON.

If AC detection needed don't forget to do the jumper settings on PCB.

Autoremove DC detection:

The amp is checking, if there is an at least 3V(DC) bias voltage provided from the installed source unit. If so, the amp turns on.

The DC voltage will only be detected on channels 1+2.

**Tech Tip:**

The wired remote line is also working in parallel to the DC detection.

② Alpine Sound Lab for PDP-E802DSP Status

Here you can find information regarding software and build versions.

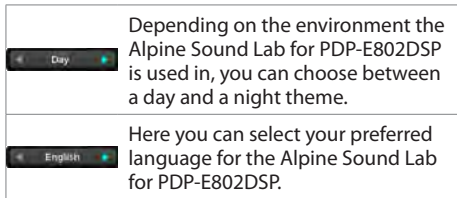
**③ Wireless Status and Settings**

This section allows to check the configuration of the wireless adapter WAD-DPD1.

Basic settings can also be made. Usually the default configuration will work fine.

ALPINE REMOTE CONTROL APP FOR PDP-E802DSP

In order to enhance the user experience of the PDP-E802DSP, we offer smartphone apps for IOS and Android. The apps allow adjustments for volume, subwoofer level, source, mute and preset selection of the PDP-E802DSP. The selection of day and night theme is also possible. Status information will be shown in real time.

Minimum requirements:

- iOS 11
- Android 7.0

Remote Control App Download:

Locate the Alpine Remote Control App for PDP-E802DSP in the respective app store. The apps are free of charge. Download and install to your device.



Wireless Connection:

When connecting via the wireless module, a connection to this module must be established via the Wi-Fi settings of your smart device or PC. Activate the Wi-Fi network search on your smart device or PC and search for the SSID "PDP-E802DSP". The default password to the network is "alpineE800".



This connection process may take 30-90 seconds before the (PDP-E802DSP) appears.

When a wireless connection has been established the wireless logo on the main configuration screen of PC software and remote app will change from gray to blue.

To initiate communication between the ALPINE Sound Lab or the ALPINE Remote app, push the power button in the app.



When the connection between app and amplifier is initiated, a pop-up message will be shown. Once it is confirmed, the connection will be established.



The ALPINE Remote App will also work in landscape mode.



USB CONNECTION FOR MUSIC PLAYBACK

The PDP-E802DSP can act like an external sound card when connected to a PC or smartphone by USB.

Minimum requirements:

- iOS 11
- Android 7.0
- Windows 10

PC Connection

Connect a Windows PC to the PDP-E802DSP's Micro USB port labeled 'PC'.

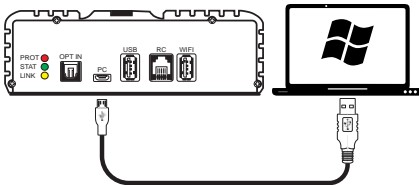

iPhone Connection

Connect an Apple device via Apple's camera connection kit to the PDP-E802DSP's Micro USB port labeled 'PC'.

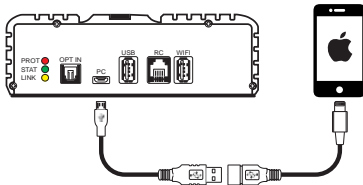

Android Connection

Connect an Android device via OTG kit to the PDP-E802DSP's Micro USB port labeled 'PC'. Host mode must be supported by the phone.

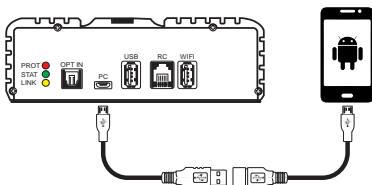

In all cases above, the source of the PDP-E802DSP needs to be set to USB using the ALPINE Sound Lab or the ALPINE Remote app.

WIRELESS STREAMING

- Audio streaming from iOS using Airplay.*
- Audio streaming from Android devices using casting apps that support UPnP/DLNA.*

* Hi-Resolution audio streaming apps required for 24-bit/92kHz audio files.

Wireless streaming with iOS

1. Connect your iOS device with the PDP-E802DSP amplifier as described in "ALPINE REMOTE CONTROL APP FOR PDP-E802DSP" on page 26.
2. Select Streaming as source within the remote app or PC software
3. Start Apple Airplay and select „PDP-E802DSP“ as destination
4. Start playback



Wireless streaming with Android Devices

1. Start a wireless connection from your Android device to the PDP-E802DSP amp as described in "ALPINE REMOTE CONTROL APP FOR PDP-E802DSP" on page 26.
2. Select Streaming as source within the remote app or PC software
3. Start your DLNA streaming app on your device and select „PDP-E802DSP“ as destination.
4. Start playback within the streaming app. Procedure and settings may differ depending on device and Android version.



SYSTEM EXAMPLES

3-way Front System + 2 Subwoofer

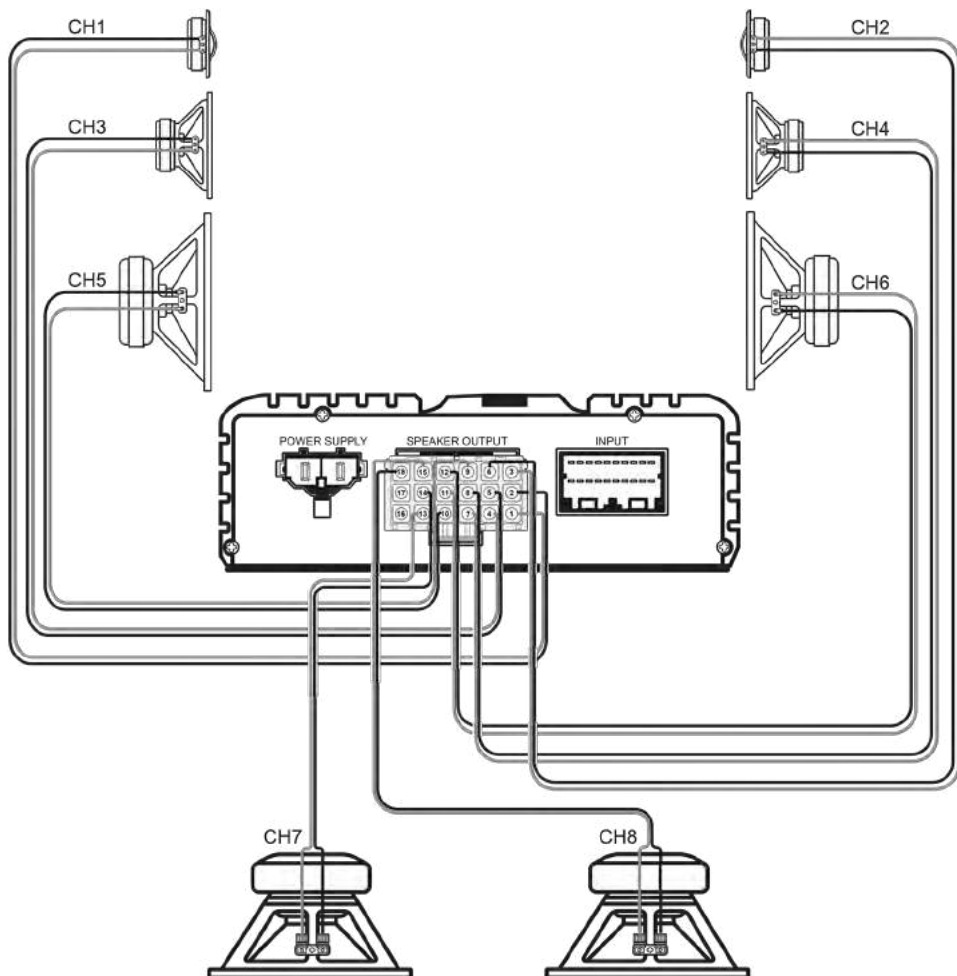

3-way Front System + 2 Subwoofer

Possible routing for this setup

Output Connections

Analog routing

	CH 1	CH 2	CH 3	Inputs	CH 4	CH 5	CH 6	Total
CH 1	100	0	0	0	0	0	0	100
CH 2	0	100	0	0	0	0	0	100
CH 3	100	0	0	0	0	0	0	100
CH 4	0	100	0	0	0	0	0	100
CH 5	100	0	0	0	0	0	0	100
CH 6	0	100	0	0	0	0	0	100
CH 7	0	0	0	0	0	50	50	100
CH 8	0	0	0	0	0	50	50	100

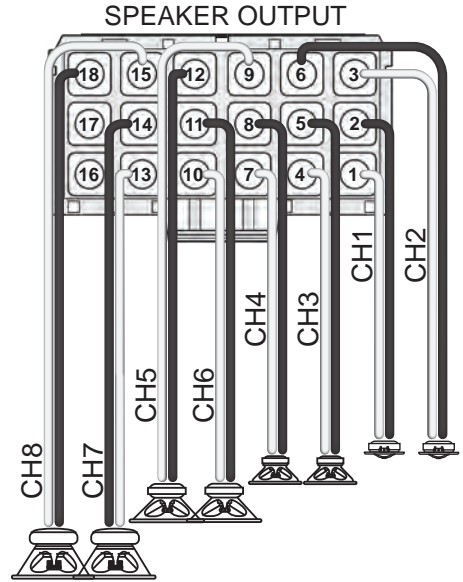

Input/ Output Assignments:

Input	Assignment	Output	Assignment
CH 1	Front Left	CH 1	Tweeter Front Left
CH 2	Front Right	CH 2	Tweeter Front Right
CH 3	Rear Left	CH 3	Midrange Front Left
CH 4	Rear Right	CH 4	Midrange Front Right
CH 5	Subwoofer 1	CH 5	Low Range Front Left
CH 6	Subwoofer 2	CH 6	Low Range Front Right
		CH 7	Subwoofer Left
		CH 8	Subwoofer Right

3-way Front System + Center + Subwoofer

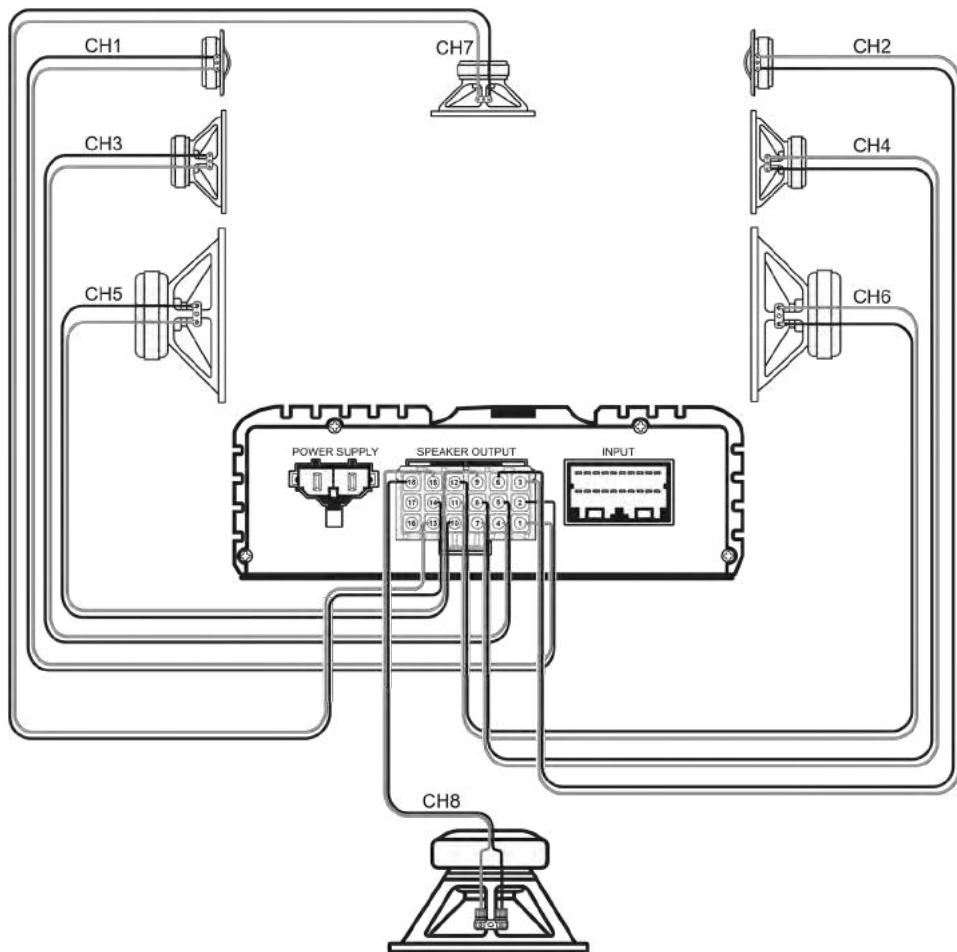

3-way Front System + Center + Subwoofer

Possible routing for this setup

Output Connections

Analog routing

	CH 1	CH 2	CH 3	CH 4	CH 5	CH 6	Total
CH 1	100	0	0	0	0	0	100
CH 2	0	100	0	0	0	0	100
CH 3	100	0	0	0	0	0	100
CH 4	0	100	0	0	0	0	100
CH 5	100	0	0	0	0	0	100
CH 6	0	100	0	0	0	0	100
CH 7	25	25	25	25	0	0	100
CH 8	0	0	0	0	50	50	100

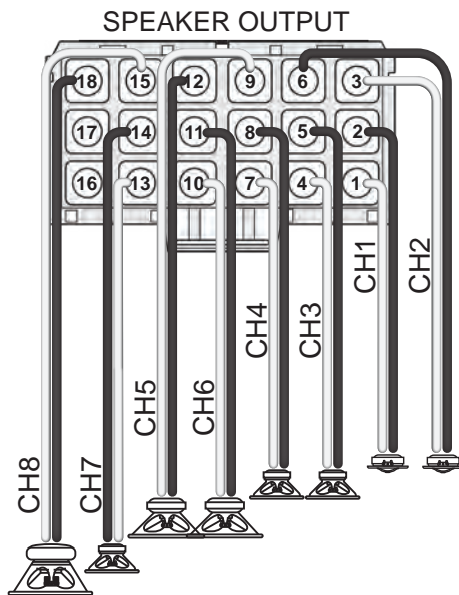

Input/ Output Assignments:

Input	Assignment	Output	Assignment
CH 1	Front Left	CH 1	Tweeter Front Left
CH 2	Front Right	CH 2	Tweeter Front Right
CH 3	Rear Left	CH 3	Midrange Front Left
CH 4	Rear Right	CH 4	Midrange Front Right
CH 5	Subwoofer 1	CH 5	Low Range Front Left
CH 6	Subwoofer 2	CH 6	Low Range Front Right
		CH 7	Center
		CH 8	Subwoofer

3-way Front System + Center + Mono Amplifier + Subwoofer

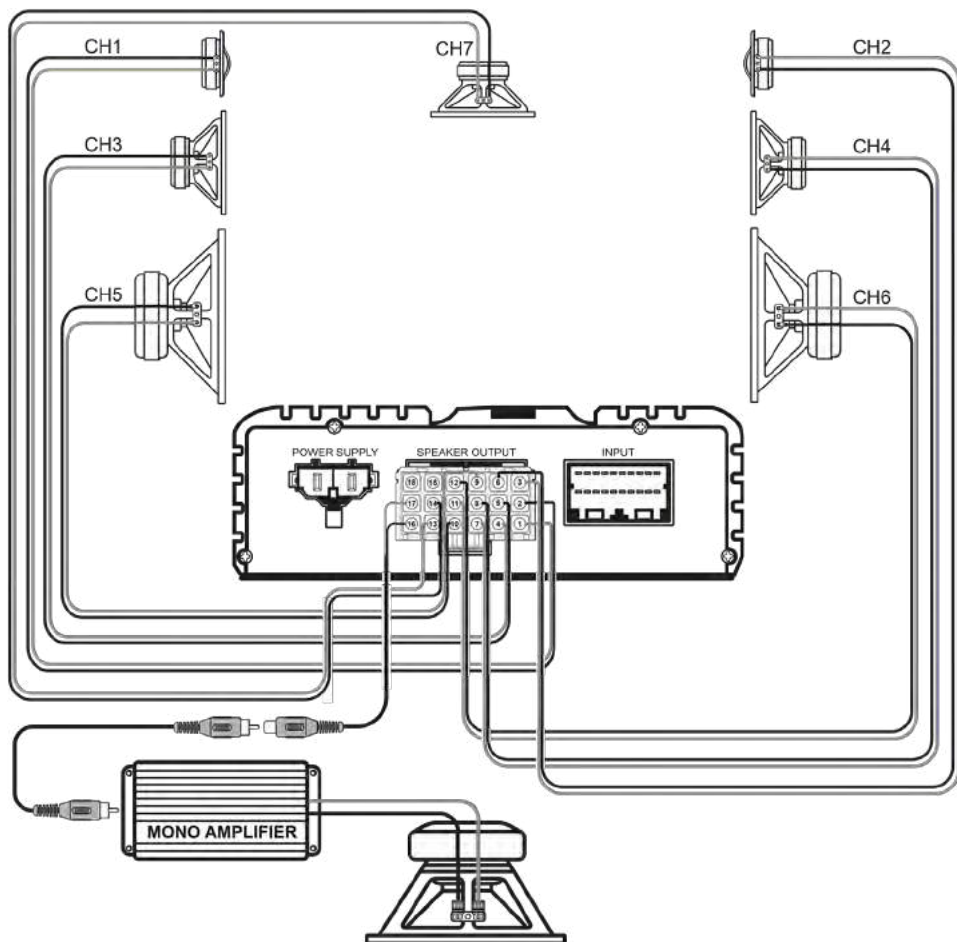

Note:

We do recommend connecting high quality amplifiers with differential RCA input/s (ground isolated) in order to avoid unwanted noise.

3-way Front System + Center + Mono Amplifier + Subwoofer

Possible routing for this setup

Output Connections

Analog routing

	CH 1	CH 2	CH 3	CH 4	CH 5	CH 6	Total
CH 1	100	0	0	0	0	0	100
CH 2	0	100	0	0	0	0	100
CH 3	100	0	0	0	0	0	100
CH 4	0	100	0	0	0	0	100
CH 5	100	0	0	0	0	0	100
CH 6	0	100	0	0	0	0	100
CH 7	25	25	25	25	0	0	100
CH 8	0	0	0	0	50	50	100

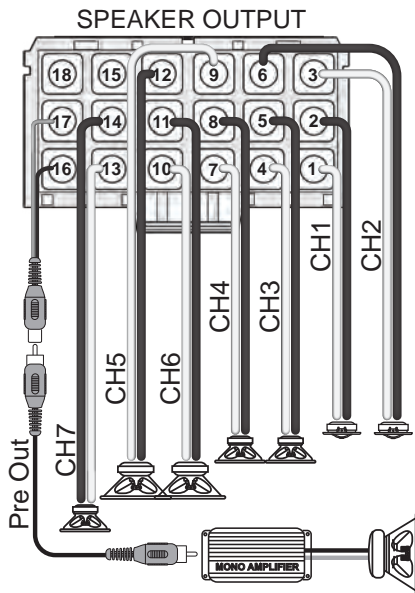

Input/ Output Assignments:

Input	Assignment	Output	Assignment
CH 1	Front Left	CH 1	Tweeter Front Left
CH 2	Front Right	CH 2	Tweeter Front Right
CH 3	Rear Left	CH 3	Midrange Front Left
CH 4	Rear Right	CH 4	Midrange Front Right
CH 5	Subwoofer 1	CH 5	Low Range Rear Left
CH 6	Subwoofer 2	CH 6	Low Range Rear Right
		CH 7	Center
		RCA	To External Amplifier

2-way Front System + 2-way Passive Rear System + 2 Subwoofer

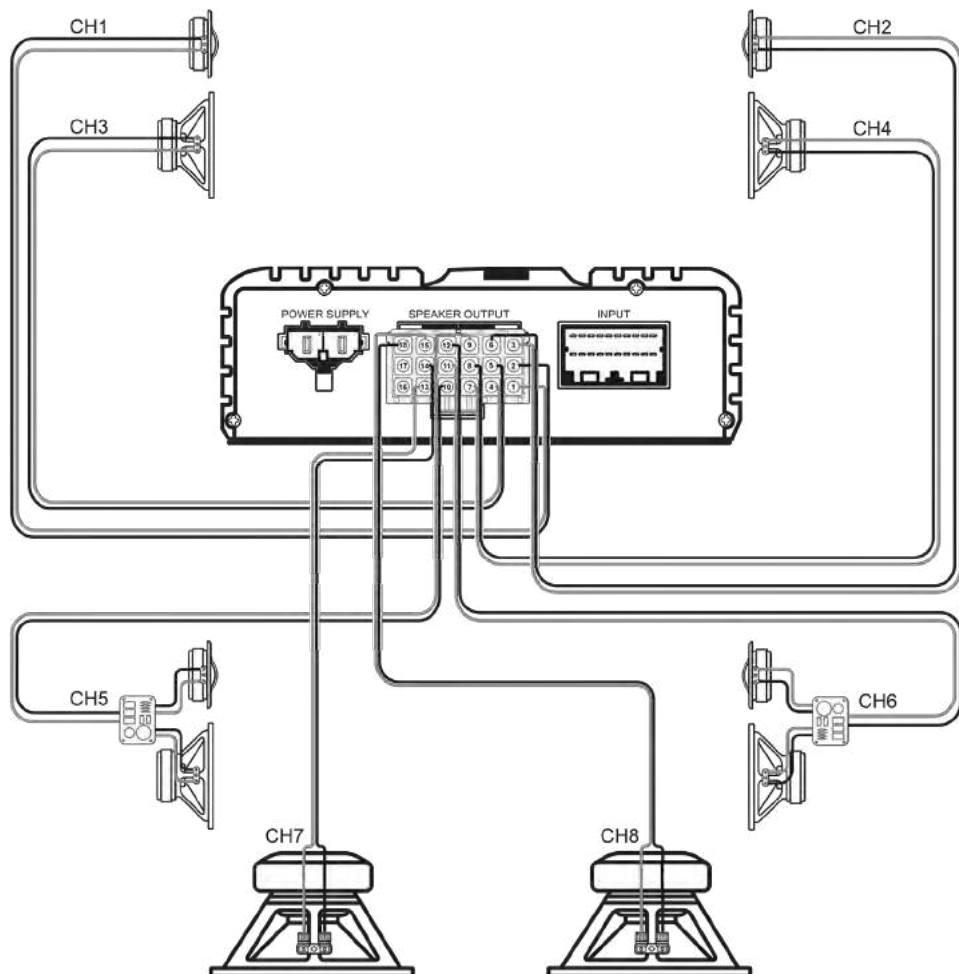

2-way Front System + 2-way Passive Rear System + 2 Subwoofer

Possible routing for this setup

Output Connections

Analog routing		Inputs						
	CH 1	CH 2	CH 3	CH 4	CH 5	CH 6	Total	
CH 1	100	0	0	0	0	0	100	
CH 2	0	100	0	0	0	0	100	
CH 3	0	0	100	0	0	0	100	
CH 4	0	0	0	100	0	0	100	
CH 5	100	0	0	0	0	0	100	
CH 6	0	100	0	0	0	0	100	
CH 7	25	25	25	25	0	0	100	
CH 8	0	0	0	0	0	100	100	

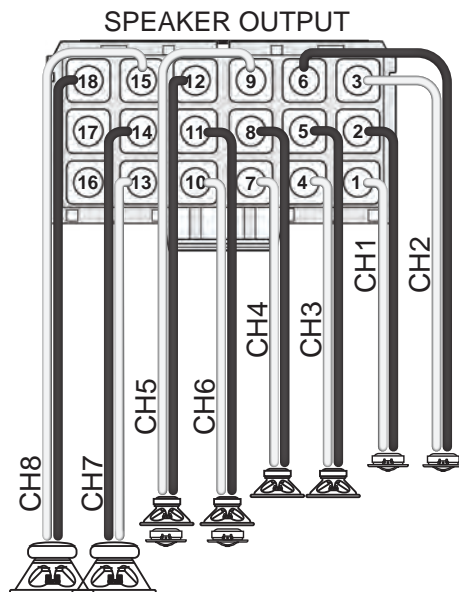

Input/ Output Assignments:

Input	Assignment	Output	Assignment
CH 1	Front Left	CH 1	Tweeter Front Left
CH 2	Front Right	CH 2	Tweeter Front Right
CH 3	Rear Left	CH 3	Low Range Front Left
CH 4	Rear Right	CH 4	Low Range Front Right
CH 5	Subwoofer 1	CH 5	Full Range Rear Left
CH 6	Subwoofer 2	CH 6	Full Range Rear Right
		CH 7	Subwoofer Left
		CH 8	Subwoofer Right

TROUBLESHOOTING

No power at DSP

- Check DSP amp main fuse under the bottom cover.
- Check vehicle battery voltage.
- Check DSP harness for a secure and low resistance ground point.
- Check Autoremote status in the app. The status should be set to "off" if using remote input wire. If this feature is on, the DSP IS waiting for an audio signal trigger from Hi-level or RCA inputs.
- Keep in mind autodetection is only available on dedicated input channels:
DC Detection: Channels 1, 2
AC Detection: Channels 5, 6
- If the amplifier is used in AC detect mode and switches off during the tuning process, the amplifier will start in update mode. In this case, the USB connection and the power connector need to be disconnected.

Low Volume while streaming from smart device

- Check device volume or streaming app volume.
- Check RC volume level.

No wireless network available

- Wireless signal could be blocked or shielded due to installation. Move wireless module to another location.
- Restart Wireless module by cycling power to the DSP.

Wireless connection is not stable

- Wireless module cables must be extended as much as possible. DO NOT bundle excess cable near the amplifier.
- Check if nearby Wi-Fi networks are transmitting on the same or neighbor channels. If so, configure the wireless module to another channel. Keep 5 channels distance to any other strong wireless network. 11 channels are available.
- Always check to see if your app firmware is up to date.

DSP app message "IN CONNECTION"

- Wireless module is connected to another device already. Disconnect all device connections and reconnect with one device only.
- Close PDP-E802DSP app.

- Cycle amplifier power to restart it.
- Reconnect PDP-E802DSP app.

Data connection to DSP not stable

- Data connection to DSP amp is active only when ALPINE Sound Lab is active. Data connection is terminated on Android devices as soon as App is working in background.
- Check if other apps in background may access the Wi-Fi data connection and terminate these Apps.

No data connection to DSP, while wireless network connection is established successfully

- Use another USB cable.
- Restart wireless module by cycling power to the DSP.
- Try hard wired connection with Windows PC by using a high quality Micro-USB cable.

You only have limited access to a setting (6 Band EQ)

- You don't have the rights to access this setting.
- Check your certificates.

FIRMWARE UPDATE

Firmware update procedure

1. Download the latest Firmware file from your local Alpine homepage.
2. Check the support area. For latest software.
3. Extract the firmware file.
4. Disconnect the power connector.
5. Connect the DSP-E802DSP to your computer (with supplied micro USB cable).
6. The amp will be recognized as disk drive.
7. Delete the old file. The firmware file has always the same name 'software.apn'. No version number is shown.



8. Drag and drop the new Firmware file to the ALPINE AMP folder.

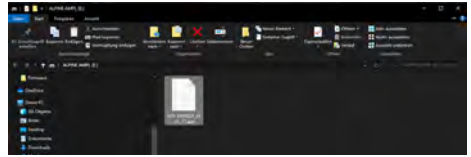

9. Reconnect power.
10. With the next amp start the new firmware will be loaded. It will automatically be renamed to „software.apn“.

SPECIFICATIONS

■ PDP-E802DSP

Performance		
Power Output	Per Channel, Ref.: 4 Ω , 14.4 V, <1% THD	100W RMS
	Per Channel, Ref.: 2 Ω , 14.4 V, <1% THD+N	120W RMS
Frequency Response		20 Hz - 22 kHz
Damping Factor		>100
Inputs		
Analogue	RCA (Low Level)	6x
	Speaker Line (High Level)	6x
Input Sensitivity	RCA (Low Level)	(10k Ω): 0.5 to 4V (rms)
	Speaker Line (High Level)	(22 Ω): 2 to 18V (rms)
Digital	Optical (S/PDIF LPCM)	12kHz - 96kHz 16bit/ 24bit
Remote In		12VDC
Outputs		
Speaker	$\geq 2\Omega$	8x
Pre-Out	Channel 8 signal, 2V RMS	1x
Remote Out	12VDC, 100mA nom.	1x
Preset Toggle	2.5VDC - 14,4VDC	1x
Digital Signal Processor		
Resolution		64bit @ 96kHz
Working Frequency		294.912MHz
Analogue Digital Converter		
S/N Ratio	Burr Brown	>105dB
Channel Separation		>75dB
THD		0.003%
Resolution		24bit @ 96kHz
General		
Operation Voltage	Start/stop compliant	11VDC - 16VDC nom.
Additional Features		Remote Auto Sensing
		2x USB Client
		1x USB Host
		Remote Port for RUX-KNOB
		Parallel mode ready
Dimensions	Width	220mm
	Height	50mm
	Depth	150mm
Weight		1.6kg

NOTE:

- Specifications and design are subject to change without notice



